

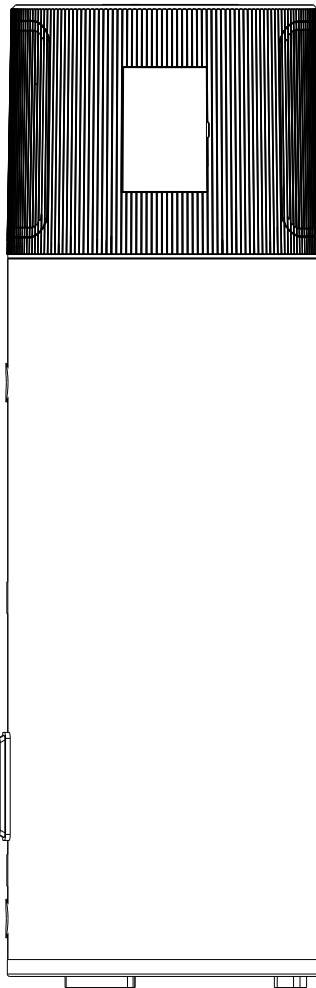

INSTALLATION AND OWNER'S MANUAL

heat-pump water heater

Residential:
PBG2-200RE-HYBRID
PBG2-250RE-HYBRID
PBG2-300RE-HYBRID



IMPORTANT NOTE:

Thank you very much for purchasing our product.
Before using your unit, please read this manual carefully and keep it for future reference.

CONTENTS

1 SAFETY PRECAUTIONS.....	01
2 PARTS AND FUNCTIONS.....	07
3 INSTALLATION INSTRUCTIONS.....	08
4 PIPELINE CONNECTION.....	10
5 ELECTRICAL CONNECTION.....	12
6 OPERATING INSTRUCTIONS.....	13
7 BEFORE FIRST USE.....	21
8 MAINTENANCE AND TROUBLE SHOOTING.....	21
9 APP CONNECTION.....	26

1 SAFETY PRECAUTIONS

To ensure your safety, please read this manual carefully before using this product.

WARNING

- Your household must have an identifiable RCBO for your hot water services.
- Leakage protection devices must be installed for household electricity.
- Do not remove any permanent instructions, labels or parameter plates on the casing of the product or inside any plates.
- The product should be installed on a tundra when installed indoors.

WARNING

- Your hot water services must be installed by a licenced electrician and licenced plumber. Improper installation may cause fire, electric shock, personal, injury, water leakage, etc.
- If your heat pump needs to be moved or relocated, please ensure you use licenced electrician and licenced plumber.
- Any modifications or repairs must be only carried out by a licenced electrician or plumber. Improper repair may cause fire, electric shock, personal, injury, water leakage and other accidents.

ATTENTIONS

- The external GPO and power plug shall be kept dry to prevent electricity leakage. Always check whether the plug and socket fit well. The inspection method is as follows: insert the power plug into the socket, start the machine for about half an hour, turn off and unplug, and check whether the pins of the plug are hot. If hot (about over 50 °C), please replace the socket with a qualified one with good contact, so as to avoid plug overheating and being burnt, or even causing fire and other personal injury accidents due to poor contact.
- In places or walls where water may splash, the external GPO shall not be installed less than 1 meters, and ensure that water will not splash on the GPO, and it shall be installed out of reach of children.
- At the cold water inlet, a 500kPa pressure limiting valve must be installed. Failure to do so will void your warranty.
- During the heating process, water drops may drip from the PTR Valve, which is normal. If there is a large amount of water leaking, please ask for your licenced plumber to return to rectify the issue. Never block the pressure relief discharge point, otherwise it may cause damage to the water heater and lead to an accident. The drain pipe connected to the pressure relief valve shall be kept inclined downward and installed in a frost-free environment and free of dirt.
- As the water temperature inside the water tank of the water heater is very high, please be careful as these temperature will exceed 50 °C will burn and cause serious injury. Be careful when using hot water. Adjust the water temperature first to avoid scalding.
- If the power cord is damaged, please ensure a licenced electrician replaces it.
- If the parts of this unit are damaged, please contact Power Bay or our recommended service partner.
- This appliance is not intended for use by persons (including children) with reduced physical, sensory or mental capabilities, or lack of experience and knowledge, unless they have been given supervision or instruction concerning use of the appliance by a person responsible for their safety. Children should be supervised to ensure that they do not play with the appliance.
- CAUTION: In order to avoid a hazard due to inadvertent resetting of the thermal cut-out, this appliance must not be connected through an external timer.
- Maximum inlet water pressure is 500kPa, minimum inlet water pressure is 150kPa.
- DANGER: Failure to operate the pressure relief valve at least once every six months may result in the water heater exploding. Continuous leakage of water from the valve may indicate a problem with the pressure relief valve.



Caution:Risk of fire/
flammable materials

! WARNING

Servicing shall only be performed as recommended by the equipment manufacturer. Maintenance and repair requiring the assistance of other skilled personnel shall be carried out under the supervision of the person competent in the use of flammable refrigerants.

Special requirements for R290

! WARNING

- Do not have refrigerant leakage and open flame.
- Be aware that the R290 refrigerant does NOT contain an odour.
- The ducts connected to an appliance shall not contain a potential ignition source.
Keep any required ventilation openings clear of obstruction

! WARNING

The appliance shall be stored so as to prevent mechanical damage and in a well-ventilated room without continuously operating ignition sources (example:open flames,an operating gas appliance) and have a room size as specified below.

! WARNING

Make sure installation,servicing,maintenance and repair comply with instruction and with applicable legislation(for example national gas regulation) and are executed only by authorized persons.

💡 NOTE

- Pipework should be protected from physical damage.
- Installation of pipework shall be kept to a minimum length.

Explanation of symbols displayed on the monobloc

	WARNING	This symbol shows that this appliance used a flammable refrigerant. If the refrigerant is leaked and exposed to an external ignition source,there is a risk of fire.
	CAUTION	This symbol shows that the operation manual shall be read carefully.
	CAUTION	This symbol shows that service personnel shall handle this equipment with reference to the installation manual.
	CAUTION	This symbol shows that a service personnel shall be handling this equipment with reference to the installation manual.
	CAUTION	This symbol shows that information is available such as the operating manual or installation manual.

WARNING

1 Information in manual

1.1 General

- information for spaces where refrigerant pipes are allowed, including statements
- that the installation of pipe-work shall be kept to a minimum;
- that pipe-work shall be protected from physical damage and, shall not be installed in an unventilated space.
- the minimum rated airflow, if required by Annex GG;
- a warning to keep any required ventilation openings clear of obstruction;
- a notice that servicing shall be performed only as recommended by the manufacturer.

2 Information on servicing

2.1 Checks to the area

Prior to beginning work on systems containing flammable refrigerants, safety checks are necessary to ensure that the risk of ignition is minimised. For repair to the refrigerating system, DD.4.3 to DD.4.7 shall be completed prior to conducting work on the system.

2.2 Work procedure

Work shall be undertaken under a controlled procedure so as to minimise the risk of a flammable gas or vapour being present while the work is being performed.

2.3 General work area

All maintenance staff and others working in the local area shall be instructed on the nature of work being carried out. Work in confined spaces shall be avoided.

2.4 Checking for presence of refrigerant

The area shall be checked with an appropriate refrigerant detector prior to and during work, to ensure the technician is aware of potentially toxic or flammable atmospheres. Ensure that the leak detection equipment being used is suitable for use with all applicable refrigerants, i.e. non-sparking, adequately sealed or intrinsically safe.

2.5 Presence of fire extinguisher

If any hot work is to be conducted on the refrigerating equipment or any associated parts, appropriate fire extinguishing equipment shall be available to hand. Have a dry powder or CO₂ fire extinguisher adjacent to the charging area.

2.6 No ignition sources

No person carrying out work in relation to a refrigerating system which involves exposing any pipe work shall use any sources of ignition in such a manner that it may lead to the risk of fire or explosion. All possible ignition sources, including cigarette smoking, should be kept sufficiently far away from the site of installation, repairing, removing and disposal, during which refrigerant can possibly be released to the surrounding space. Prior to work taking place, the area around the equipment is to be surveyed to make sure that there are no flammable hazards or ignition risks. "No Smoking" signs shall be displayed.

2.7 Ventilated area

Ensure that the area is in the open or that it is adequately ventilated before breaking into the system or conducting any hot work. A degree of ventilation shall continue during the period that the work is carried out. The ventilation should safely disperse any released refrigerant and preferably expel it externally into the atmosphere.

2.8 Checks to the refrigerating equipment

Where electrical components are being changed, they shall be fit for the purpose and to the correct specification. At all times the manufacturer's maintenance and service guidelines shall be followed. If in doubt, consult the manufacturer's technical department for assistance.

The following checks shall be applied to installations using flammable refrigerants:

- the actual refrigerant charge is in accordance with the room size within which the refrigerant containing parts are installed;
- the ventilation machinery and outlets are operating adequately and are not obstructed;
- if an indirect refrigerating circuit is being used, the secondary circuit shall be checked for the presence of refrigerant;
- marking to the equipment continues to be visible and legible. Markings and signs that are illegible shall be corrected;
- refrigerating pipe or components are installed in a position where they are unlikely to be exposed to any substance which may corrode refrigerant containing components, unless the components are constructed of materials which are inherently resistant to being corroded or are suitably protected against being so corroded.

WARNING

2.9 Checks to electrical devices

Repair and maintenance to electrical components shall include initial safety checks and component inspection procedures. If a fault exists that could compromise safety, then no electrical supply shall be connected to the circuit until it is satisfactorily dealt with. If the fault cannot be corrected immediately but it is necessary to continue operation, an adequate temporary solution shall be used. This shall be reported to the owner of the equipment so all parties are advised.

Initial safety checks shall include:

- that capacitors are discharged: this shall be done in a safe manner to avoid possibility of sparking;
- that no live electrical components and wiring are exposed while charging, recovering or purging the system;
- that there is continuity of earth bonding.

3 Repairs to sealed components

3.1 During repairs to sealed components, all electrical supplies shall be disconnected from the equipment being worked upon prior to any removal of sealed covers, etc. If it is absolutely necessary to have an electrical supply to equipment during servicing, then a permanently operating form of leak detection shall be located at the most critical point to warn of a potentially hazardous situation.

3.2 Particular attention shall be paid to the following to ensure that by working on electrical components, the casing is not altered in such a way that the level of protection is affected. This shall include damage to cables, excessive number of connections, terminals not made to original specification, damage to seals, incorrect fitting of glands, etc.

Ensure that the apparatus is mounted securely.

Ensure that seals or sealing materials have not degraded to the point that they no longer serve the purpose of preventing the ingress of flammable atmospheres. Replacement parts shall be in accordance with the manufacturer's specifications.

4 Repair to intrinsically safe components

Do not apply any additional loads to the circuit without ensuring that this will not exceed the permissible voltage and current permitted for the equipment in use. Intrinsically safe components are the only types that can be worked on while live in the presence of a flammable atmosphere. The test apparatus shall be at the correct rating.

Replace components only with parts specified by the manufacturer. Other parts may result in the ignition of refrigerant in the atmosphere from a leak.

NOTE The use of silicon sealant can inhibit the effectiveness of some types of leak detection equipment.

Intrinsically safe components do not have to be isolated prior to working on them.

5 Cabling

Check that cabling will not be subject to wear, corrosion, excessive pressure, vibration, sharp edges or any other adverse environmental effects. The check shall also take into account the effects of aging or continual vibration from sources such as compressors or fans.

6 Detection of flammable refrigerants

Under no circumstances shall potential sources of ignition be used in the searching for or detection of refrigerant leaks. A halide torch (or any other detector using a naked flame) shall not be used.

The following leak detection methods are deemed acceptable for all refrigerant systems.

Electronic leak detectors may be used to detect refrigerant leaks but, in the case of flammable refrigerants, the sensitivity may not be adequate, or may need re-calibration. (Detection equipment shall be calibrated in a refrigerant-free area.) Ensure that the detector is not a potential source of ignition and is suitable for the refrigerant used. Leak detection equipment shall be set at a percentage of the LFL of the refrigerant and shall be calibrated to the refrigerant employed, and the appropriate percentage of gas (25 % maximum) is confirmed.

Leak detection fluids are also suitable for use with most refrigerants but the use of detergents containing chlorine shall be avoided as the chlorine may react with the refrigerant and corrode the copper pipe-work.

NOTE Examples of leak detection fluids are

- bubble method,
- fluorescent method agents.

If a leak is suspected, all naked flames shall be removed/extinguished.

If a leakage of refrigerant is found which requires brazing, all of the refrigerant shall be recovered from the system, or isolated (by means of shut off valves) in a part of the system.

Prior to recharging the system, it shall be pressure-tested with the appropriate purging gas.

The system shall be leak-tested on completion of charging but prior to commissioning. A follow up leak test shall be carried out prior to leaving the site.

7 Decommissioning

Before carrying out this procedure, it is essential that the technician is completely familiar with the equipment and all its detail. It is recommended good practice that all refrigerants are recovered safely. Prior to the task being carried out, an oil and refrigerant sample shall be taken in case analysis is required prior to re-use of recovered refrigerant. It is essential that electrical power is available before the task is commenced.

- a) Become familiar with the equipment and its operation.
- b) Isolate system electrically.
- c) Before attempting the procedure, ensure that:
 - mechanical handling equipment is available, if required, for handling refrigerant cylinders;
 - all personal protective equipment is available and being used correctly;
 - the recovery process is supervised at all times by a competent person;
 - recovery equipment and cylinders conform to the appropriate standards.
- d) Pump down refrigerant system, if possible.
- e) If a vacuum is not possible, make a manifold so that refrigerant can be removed from various parts of the system.
- f) Make sure that cylinder is situated on the scales before recovery takes place.
- g) Start the recovery machine and operate in accordance with instructions.
- h) Do not overfill cylinders (no more than 80 % volume liquid charge).
- i) Do not exceed the maximum working pressure of the cylinder, even temporarily.
- j) When the cylinders have been filled correctly and the process completed, make sure that the cylinders and the equipment are removed from site promptly and all isolation valves on the equipment are closed off.
- k) Recovered refrigerant shall not be charged into another refrigerating system unless it has been cleaned and checked.

 **WARNING**

8 Labeling

Equipment shall be labelled stating that it has been de-commissioned and emptied of refrigerant. The label shall be dated and signed. For appliances containing flammable refrigerants, ensure that there are labels on the equipment stating the equipment contains flammable refrigerant.

9 Recovery

When removing refrigerant from a system, either for servicing or decommissioning, it is recommended good practice that all refrigerants are removed safely.

When transferring refrigerant into cylinders, ensure that only appropriate refrigerant recovery cylinders are employed. Ensure that the correct number of cylinders for holding the total system charge is available. All cylinders to be used are designated for the recovered refrigerant and labelled for that refrigerant (i.e. special cylinders for the recovery of refrigerant). Cylinders shall be complete with pressure-relief valve and associated shut-off valves in good working order. Empty recovery cylinders are evacuated and, if possible, cooled before recovery occurs.

The recovery equipment shall be in good working order with a set of instructions concerning the equipment that is at hand and shall be suitable for the recovery of all appropriate refrigerants including, when applicable, flammable refrigerants. In addition, a set of calibrated weighing scales shall be available and in good working order. Hoses shall be complete with leak-free disconnect couplings and in good condition. Before using the recovery machine, check that it is in satisfactory working order, has been properly maintained and that any associated electrical components are sealed to prevent ignition in the event of a refrigerant release. Consult manufacturer if in doubt.

The recovered refrigerant shall be returned to the refrigerant supplier in the correct recovery cylinder, and the relevant waste transfer note arranged. Do not mix refrigerants in recovery units and especially not in cylinders.

If compressors or compressor oils are to be removed, ensure that they have been evacuated to an acceptable level to make certain that flammable refrigerant does not remain within the lubricant. The evacuation process shall be carried out prior to returning the compressor to the suppliers. Only electric heating to the compressor body shall be employed to accelerate this process. When oil is drained from a system, it shall be carried out safely.

Do not use means to accelerate the defrosting process or to clean, other than those recommended by the manufacturer.

The appliance shall NOT be stored in a room with continuously operating ignition sources (for example: open flames, an operating gas appliance or an operating electric heater).

Do not pierce or burn.

Be aware that the refrigerants may not contain an odour.

1. General

Ensure the installation of pipe-work shall be kept to a minimum

Ensure that pipe-work shall be securely protected from physical damage.

Compliance with national gas regulations shall be observed.

Ensure mechanical connections be accessible for maintenance purposes.

Do not instal, operate or store the device in a room with a floor area smaller than 180m² as specified in section 3.1 Selection of instalalltion site

Disposal of equipment using flammable refrigerants - see national regulations.

Keep any required ventilation openings clear of obstruction.

Servicing shall only be performed as recommended by the equipment manufacturer. Maintenance and repair requiring the assistance of other skilled personnel shall be carried out under the supervision of the person competent in the use of flammable refrigerants.

Any person who is involved with working on or breaking into a refrigerant circuit should hold a current valid certificate from an industry accredited assessment authority, which authorises their competence to handle refrigerants safely in accordance with an industry recognised assessment specification.

ATTENTIONS

- The fixed wiring insulation must be protected, for example, by insulating sleeving having an appropriate temperature rating.
- If the water supply pressure exceeds the rated pressure, a pressure reducing valve is to be fitted in the installation.
- Water heater is permanently connected to water mains.
- A typical value of acceptable water hardness or total dissolved solids is 600mg/Liter.
If you are unsure about water quality and suitability, contact your water authority.

! WARNING

- Warning for continued safety of this appliance it must be installed, operated and maintained in accordance with the manufacturer's instructions.
- Warning this appliance may deliver water at high temperature. Refer to the plumbing code of australia(pca), local requirements and installation instructions to determine if additional delivery. A temperature limiting device such as a tempering valve, will be required on hot water system.
- If hot water system isn't used for 2 weeks or more, a quantity of HIGHLY flammable hydrogen gas may accumulate in the water heater. To dissipate this gas safely, it is recommended that a hot tap be turned on for several minutes or until discharge of gas ceases. Use a sink, basin, or bath outlet, but not a dishwasher, clothes washer or other appliance. During this procedure, there must be no smoking, open flame or any electrical appliance operating nearby. If hydrogen is discharged.

! ATTENTIONS

- Your hot water services should be plumbed to your household supply.
- Your hot water services shall be installed in accordance with AS/NZS 3000 regulations.
- Instruction concerning disconnection incorporated in the fixed wiring is in accordance with AS/NZS 3000.
- Installed in compliance with Australian plumbing standard AS3500.4.
- It is recommended that the temperature of this product's thermostat be set to 60 °C.
- The external GPO of the machine must be protected by an RCBO.

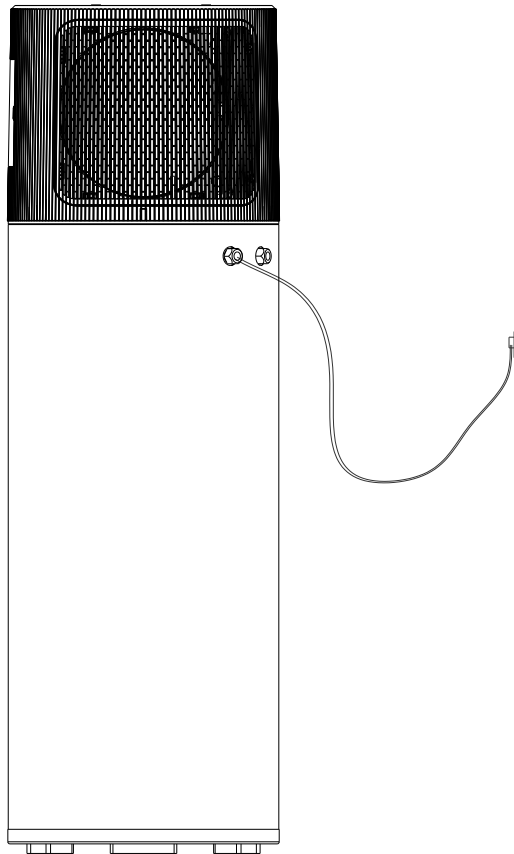

! ATTENTIONS

- If the water temperature is higher than 95 °C, the TCO will automatically shut off the power of E-heater, it must be reset by an authorised service technician.
- Water operating temperatures between 30 °C and 60 °C.
- Water operating pressures between 150kPa and 500kPa.

💡 NOTE

- This product complies with the Lead-Free requirements of the National Construction Code Volume Three.

2 PARTS AND FUNCTIONS

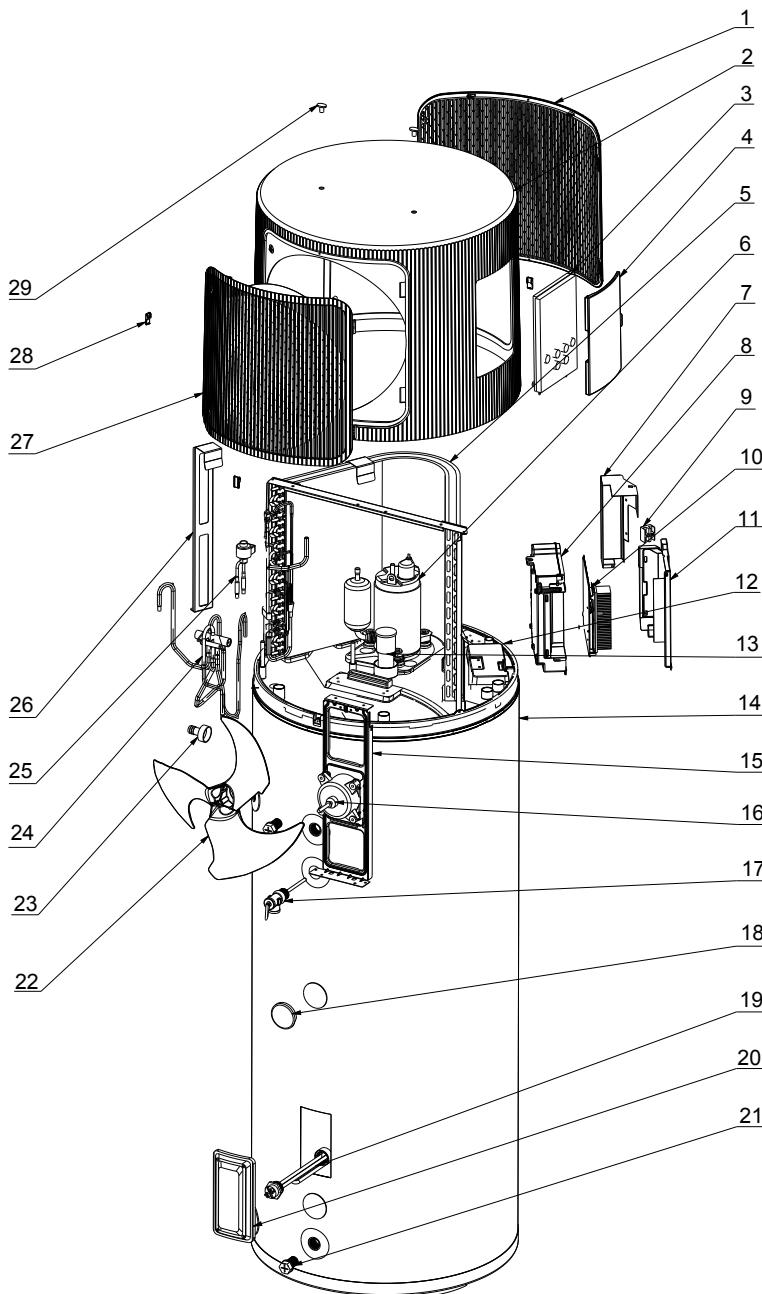

SN	Name	Number
1	Air intake grille	1
2	Outer cover	1
3	Display box assembly	1
4	Display shield	1
5	Evaporator	1
6	Compressor	1
7	Terminal block cover	1
8	Electrical box	1
9	Terminal	1
10	Main control board	1
11	Electronic control box cover component	1
12	Drainage tray	1
13	magnesium rod	1
14	water tank assembly	1
15	Motor bracket assembly	1
16	Fan motor	1
17	PTR valve	1
18	Temperature measuring port seal cover	2
19	Electric heating	1
20	Electric heating cable cover	1
21	External thread inlet and outlet water plug	2
22	Fan	1
23	Drain nozzle	1
24	Four-way valve assembly	1
25	Electronic expansion valve assembly	1
26	Evaporator rear fixing plate	1
27	Outlet grille	1
28	Decorative screw cap	3
29	Hole cap	2

NOTE

- This diagram is only for reference, and the appearance of the product may not be the same as that of the real object. Subject to the actual model.

3 INSTALLATION INSTRUCTIONS

3.1 Selection of installation site

- It is not recommended to install this water heater indoors. If it is installed indoors, problems such as overflow, noise and indoor temperature drop may occur, which will affect your normal life.
 - Adequate installation and maintenance space shall be available.
 - No barrier at the inlet and outlet.
 - Well ventilated space.
 - It is recommended that your heat pump is installed on one of the following:
 1. existing concrete slab
 2. 600x600x50mm concrete slab
 3. Rectorseal poly slab for hot water serviceThe horizontal line should't be greater than 2 degrees.
 - Running noise and exhaust air shall not affect neighbors.
 - No combustible gas leakage.
 - Convenient for plumbing connection and electrical connection.
- Recommended for outdoor installation. For indoor installation, a minimum area of 180m² must be met.

3.2 Handling

- This unit is heavy, it weighs more than 100kg, and it's recommended for two people to handle and install.
- Please handle the unit by maintaining its ex-factory status, and do not disassemble and assemble it by yourself.
- In order to avoid abrasion and deformation on the surface of the unit, please put a guard plate on the surface of the unit in contact with hard objects.
- Please be careful not to make your hands or other objects come into contact with the fan blades.
- Do not tilt greater than 15° handling, and it is strictly prohibited to lie down.

3.3 Installation

- If the unit is installed in basement, indoor or other confined spaces, pay attention to the circulation of exhaust and intake of air around the indoor and outdoor unit;
- Please ensure the sufficient space for installation and maintenance.
- Installation to confirm with AS/NZS 3500.4.

3.4 Space required for installation and maintenance

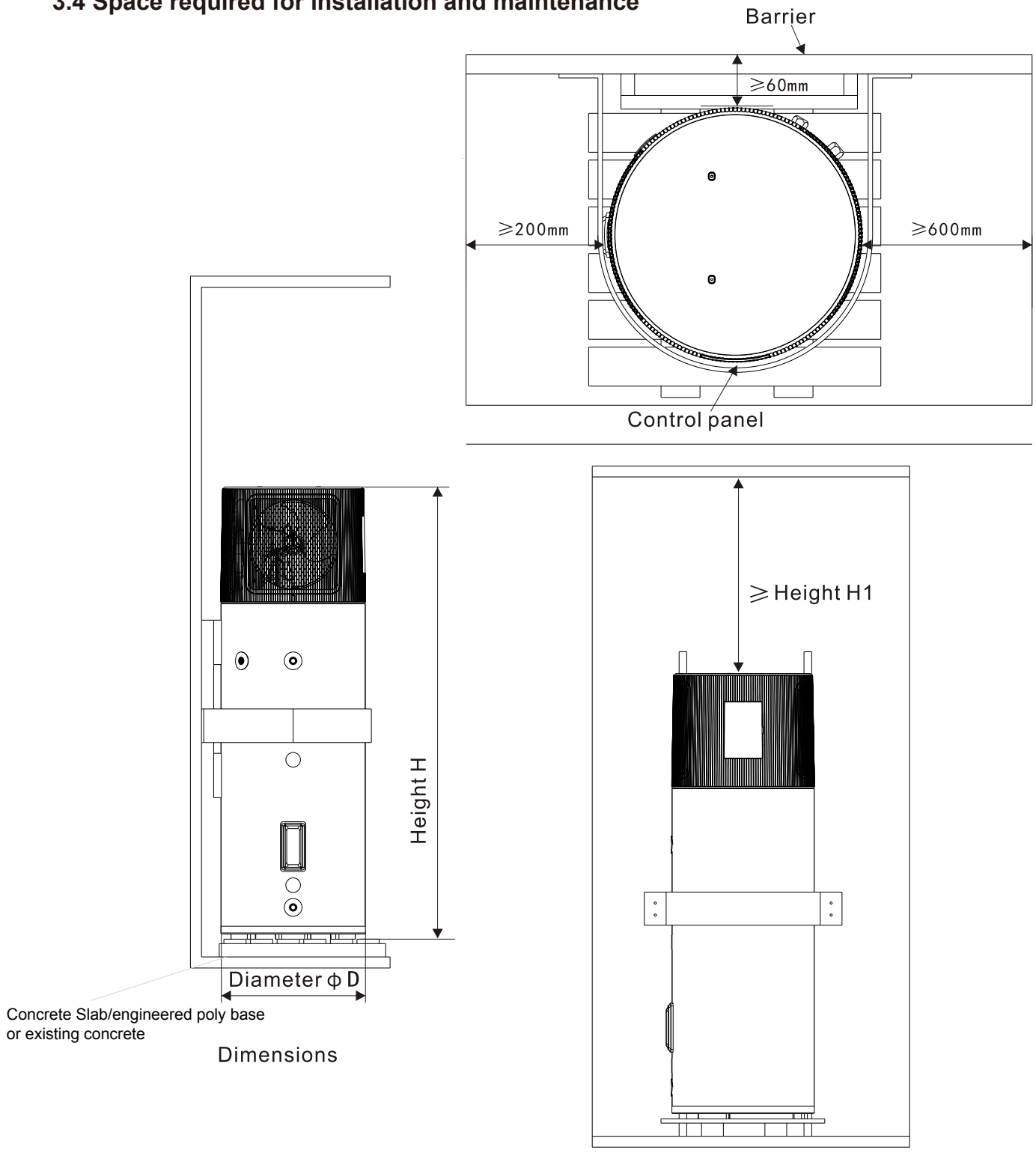

Dimension parameters

Parameter \ Model	PBG2-200RE-HYBRID	PBG2-250RE-HYBRID	PBG2-300RE-HYBRID
Diameter ϕD (mm)	650	650	650
Height H(mm)	1890	1950	2030
Height H1(mm)	800	800	800

4 PIPELINE CONNECTION

4.1 Pipeline connection diagram

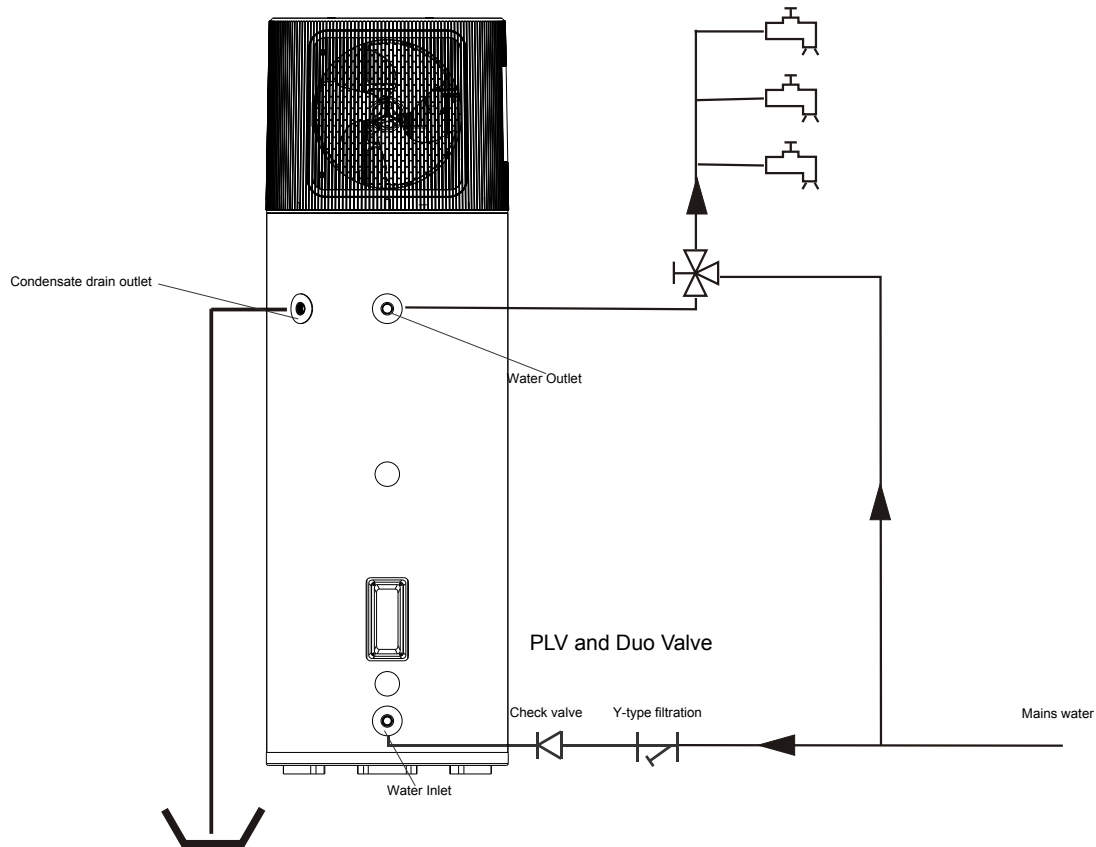

NOTE

- Screw the drain port stainless steel cover, then water heater can be drained.
- Operating temperatures range: 1~95 °C
- Pressure of water system: 500kPa
- Pressure relief valve rated pressure : 850kPa. (Supplier: Zhuhai Edison Smart Home Co., Ltd)
- Means for disconnection must be incorporated in the fixed wiring in accordance with the wiring rules.

4.2 Pipeline connection instructions

ATTENTIONS

- Do not install the water heater with iron pipes. Water systems shall only use new pipes that meet drinking water standards, such as CPVC, PPR pipes or polybutene pipes. Do not use PVC water pipes;
- Water pipes and fittings shall be installed according to the above figure. All water pipes must be insulated.

- Installation of water inlet and outlet connecting pipe: The thread specification of water inlet and outlet of this machine is G3/4"(internal thread). The service life of pipes and fittings used for installation and connection shall not be less than the service life of the water heater, and shall have sufficient high temperature resistance to prevent damage;
- Installation of temperature and pressure safety valve: the specification of temperature and pressure installation valve is Rc3/4"(inner tooth), 850kPa. After installation according to the pipeline connection diagram, remove the bolts for fixing the safety valve handle and ensure that the outlet of the connected drain pipe is led the air;

ATTENTIONS

- The pressure relief valve shall be pulled once every six months to remove calcium carbonate deposits. And make sure the device is not blocked. The water temperature at outlet may be very high, so pay attention to avoid scalding;
- The drain pipe shall be insulated to avoid being frozen in winter and causing safety accidents.

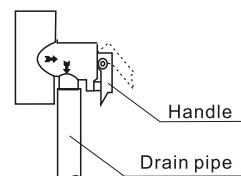

! DANGER

- Do not press down the safety valve handle.
- Never remove the safety valve.
- Never block the drain port.
- The drain pipe shall be led to an open drain outlet.



- After all pipelines are installed, open the cold water inlet valve and the hot water outlet valve, and start to fill the tank. When the water outlet is normally discharged, it indicates that the water in the water tank has been filled. Close the outlet valve and check whether there is water leakage at the joints of all pipelines. If there is water leakage, it shall be repaired and then injected for inspection.
- If the inlet water pressure is less than 150kPa, in order to get a larger water flow, please install a booster pump at the inlet pipe to ensure the inlet water pressure not less than 150kPa. If the water supply pressure is greater than 500kPa, in order to ensure the long-term safe use of your water tank, please install the pressure reducing valve at the water inlet pipe.
- During operation, condensed water droplets may occur at the air outlet, and the water outlet may be accidentally blocked. In such cases, water droplets will come out from the surface of the unit. To ensure that your life will not be affected or your belongings be damaged, it is recommended to use a water pan to collect the condensed water. Please refer to the following figure.
- To smoothly drain condensate from unit, please install the main unit is on level surface. Otherwise, please ensuring the drain vents at the lowest place. Recommended inclination angle of unit must be installed on level ground°.

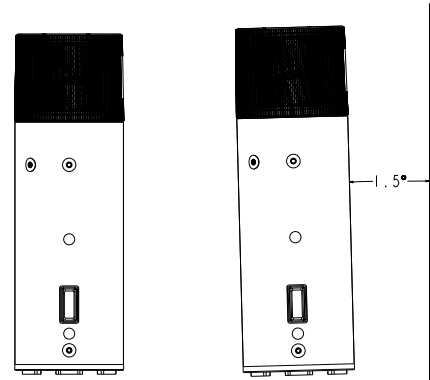
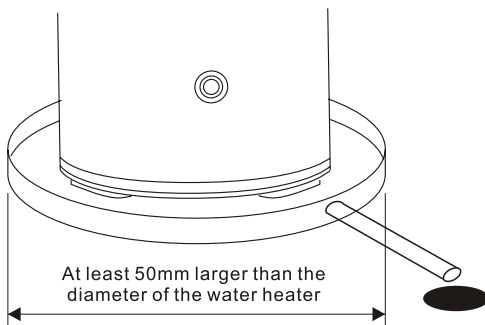

! ATTENTIONS

If the unit is installed at outdoor places where the temperature is below 0°C, all copper pipe must be installed and covered with lagging to prevent pipes freezing and mperature loss.

4.3 Electrical wiring

! ATTENTIONS

- The water heater shall be plugged in to an external GPO protected by an RCBO.
- Electrical installation and connection to be done by a licenced electrical contractor.
- After all wiring work is completed, check carefully before switching on the power.

4.4 Recommended power supply specifications

Project Model	Powersupply	Wire diameter(mm ²)		Curcuit breaker(A)	Leakageprotector
		Dimensions (Continuous length ≤ 30m)	Grounding wire	Capacity	
PBG2-200RE-HYBRID	220V-240V~50Hz	≥2.5	≥2.5	25	30mA Below 0.1 sec
PBG2-250RE-HYBRID	220V-240V~50Hz	≥2.5	≥2.5	25	30mA Below 0.1 sec
PBG2-300RE-HYBRID	220V-240V~50Hz	≥2.5	≥2.5	25	30mA Below 0.1 sec

5 USAGE METHODS

When using, please operate by the following order:

Water affusion:When the unit is used for the first time(or the water tank is emptied and used again), the user must check that it has been filled with water before power-on. water affusion method (see the following figure)

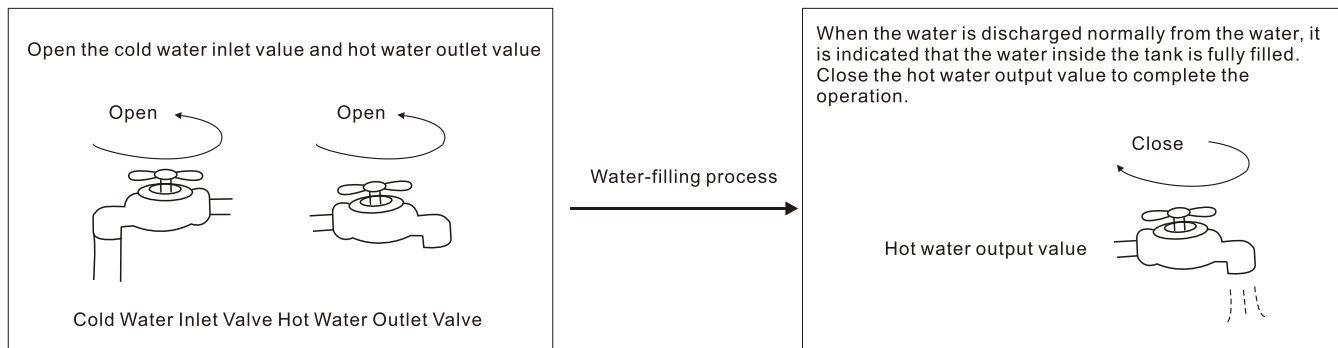

! WARNING

- If an electric auxiliary heating unit is turned on when there is no water in the water tank, it will cause damage to the electric heating device.

Turn on the power, the display screen lights up, indicating that the unit has been powered on. Users can switch different modes by pressing relevant keys on the display screen(see the next page for details)

! WARNING

- If the water temperature exceeds 50 °C , it may cause severe burns and even death.
- Children, the disabled and the elderly are at the highest risk of scalding.
- Please adjust to the proper water temperature first before bathing or using.

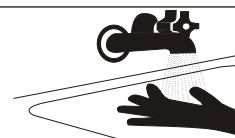

Water effusion:When cleaning and moving the machine,drain the water heater. Effusion method(see figure below)

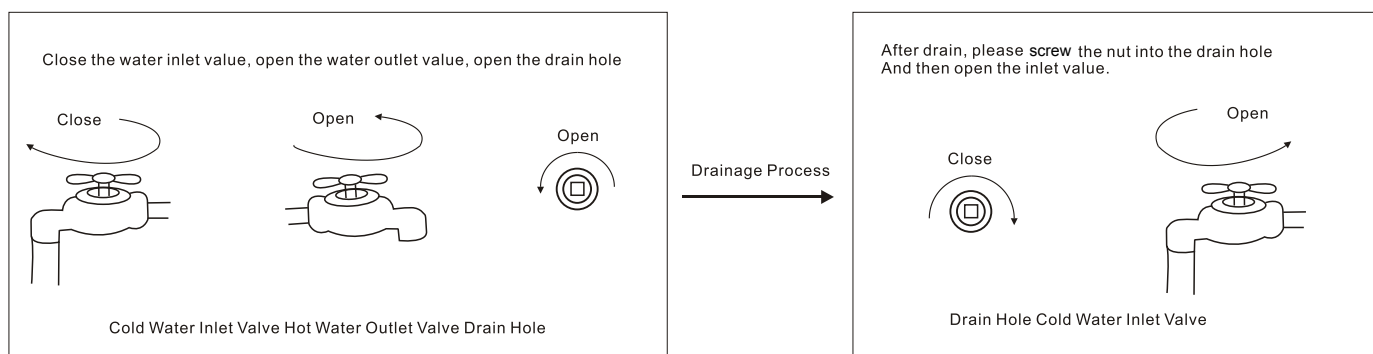





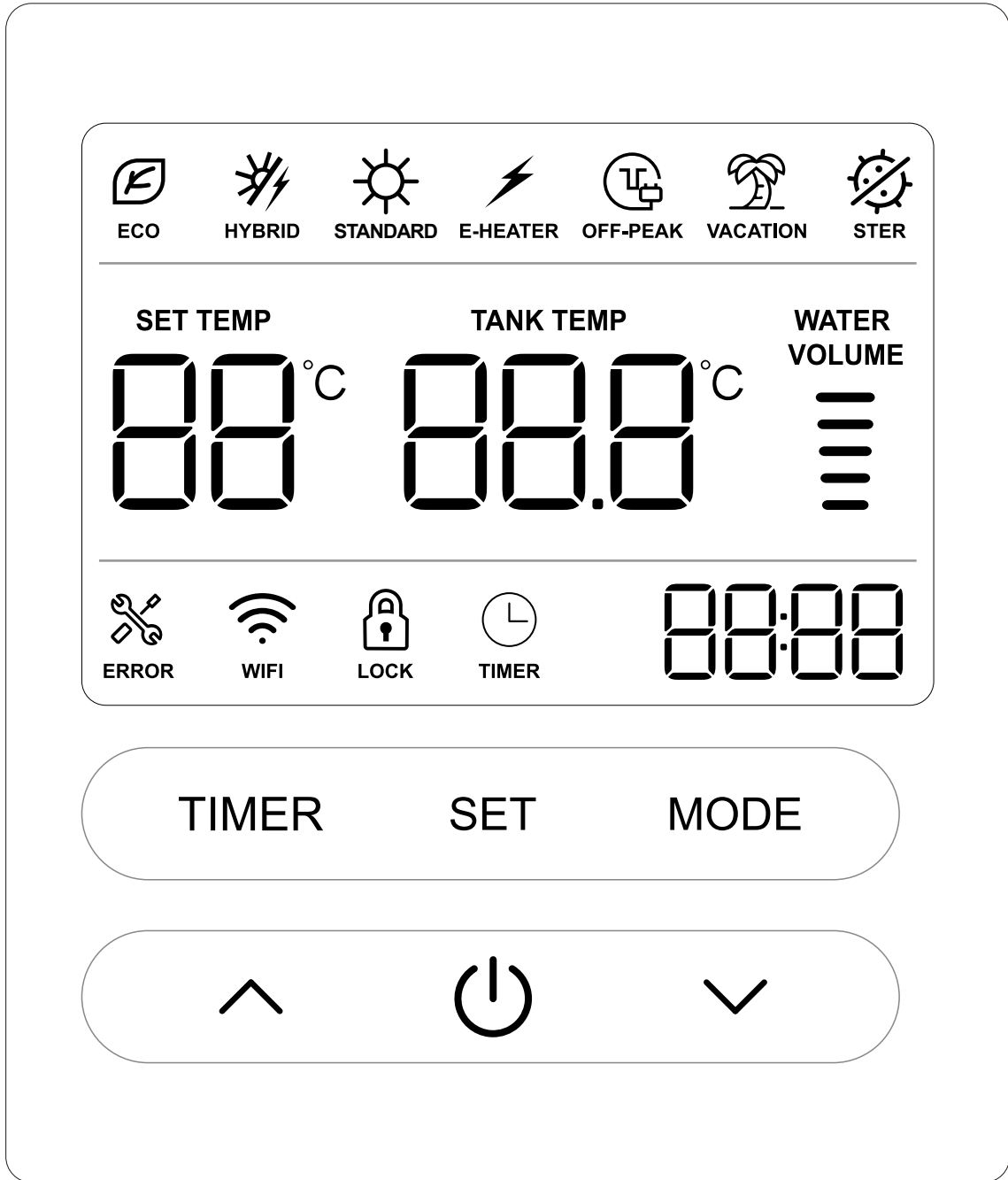









6 OPERATING INSTRUCTIONS





6.1 Display screen and operation panel



6.2 Display screen and operation panel

NO	Symbol	Description	
1	 ECO	ECO mode	This icon will be shown when ECO mode is activated. The range of setting temperature is 30 ~ 60 C .
2	 HYBRID	Hybrid mode	This icon will be shown when Hybrid mode is activated. The range of setting temperature is 30 ~ 70 C .
3	 STANDARD	Standard mode	This icon will be shown when Standard mode is activated. The range of setting temperature is 30 ~ 70 C .
4	 SET TEMP 00°C	Set temperature	This icon shows the set temperature of water tank.
5	 ERROR	Error	This icon will be shown when there is an error.
6	 TIMER	Timer	This icon will be shown when the timer is activated.
7	 OFF-PEAK	Off-peak mode	This icon will be shown when Off-peak mode is activated. You need to activate Off-peak mode in the APP.
8	 WATER VOLUME	Water volume	This icon shows the current water volume of the water tank.
9	 VACATION	Vacation mode	This icon will be shown when Vacation mode is activated.
10	 STER	Sterilization mode	This icon will be shown when Sterilization mode is activated.
11	 LOCK	Child lock	This icon will be shown when Child lock mode is activated.
12	 TANK TEMP 000°C	Tank temperature	This icon shows the current water tank temperature.
13	 WIFI	Wifi	This icon will be shown when you have connected the Wifi.
14	 00:00	Clock	This icon shows the real time clock.
15	 E-HEATER	Electric heater	This icon will be shown when the electric heater is activated.

6.3 Button Description

NO	Symbol	Description	
1	SET	Function settings	Press this button and hold it for 3 seconds to enter the parameter query interface.
2	TIMER	Timer	Press this button and hold it for 3 seconds could set the clock; Anytime you press Timer button, you could set the timer of water heater;
3	MODE	Mode setting	Change the running mode of water heater between Eco mode, Hybrid mode and Standard mode; Press this button and hold it for 3 seconds could turn on/off the Child lock function.
4		On/off	To turn the unit on/off.
5		Increase/Up	Increase the target temperature; Increase the set time of timer/clock. Page up of parameters display and error display;
6		Decrease/Down	Decrease the target temperature; Decrease the set time of timer/clock. Page down of parameters display and error display;
7	SET + 	Function settings+Up	Press Function settings and Up button at the same time for 3 seconds to enter parameters query interface.
8	SET + 	Function settings+On/off	Press Function settings and On/off button at the same time for 3 seconds to match Wifi.

6.4 Operation

6.4.1 Mode set

Press the Mode setting button, you can select the operating mode you want including ECO mode, Hybrid mode and Standard mode;

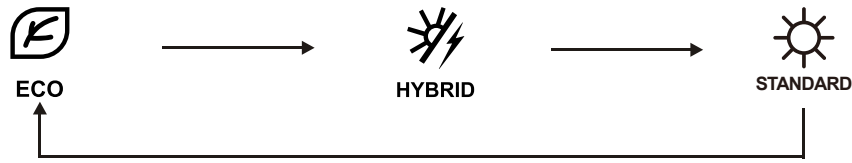
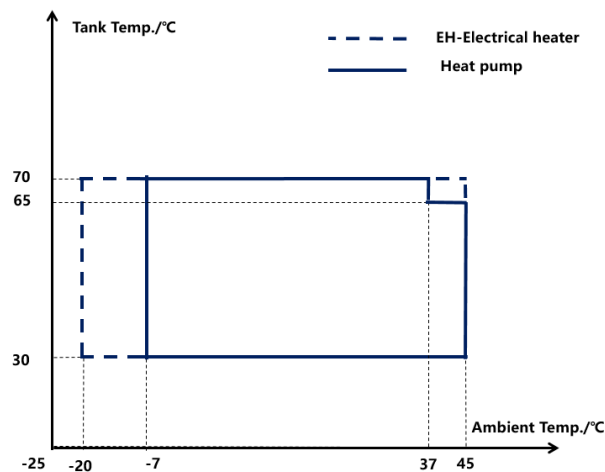

Figure 2.1 Mode selection

- The standard mode is the default mode when you install the water heater for the first time;
- Those mode icon which you have selected will show up and no need to press additional button to confirm it;
- In ECO mode, only water heater will turn on;
- In Hybrid mode, the water heater and electrical heater will turn on together and when the water tank temperature is higher than the limited value of water heater, it will turn off ;
- In Standard mode, the water heater will turn on at the beginning and when the water tank temperature is higher than the limited value of water heater, it will turn off and electrical heater will turn on. This mode is not available for the models without electric heater.
- The operation range of water heater is shown as below;
- The heat pump water heater will set back to Standard mode if it had run in ECO mode or Hybrid mode for 24h.



6.4.2 Temperature set

Press the \wedge or \vee button to increase or decrease the target water tank temperature.

- When you are setting, the mode icon will flashing each second;
- Each time you press \wedge or \vee button, the target temperature will be changed by 1°C;
- If you hold the \wedge or \vee button for 3 seconds above, the target temperature will increase or decrease 10°C in each 2 seconds;
- If the temperature is out of the limit, the buzzer will ring to remind you and the Tank temperature will keep the limited value;
- If there is no operation for 5 seconds, the display will go back to the main display.

6.4.3 Turn on/off

After confirming the mode and target temperature, you could press \odot button to control the status of water heater.

- When the unit is off, if you press the \odot button, the water heater will turn on;
- When the unit is on, if you press the \odot button, the water heater will turn off.

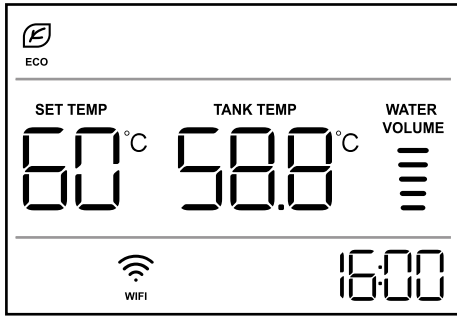

Figure 2.2 Turn on

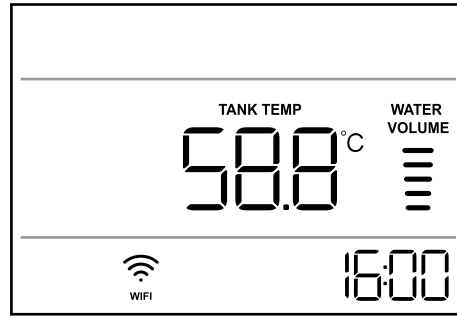

Figure 2.3 Turn off

The mode and set temperature icons will show up when the water heater turns on. Turn off some indicators on the screen after 30 seconds. If any operation occurs, turn on the screen for 30 seconds and then turn off; You can switch between fully on or partially on the display light by holding down the 3S combination key [MODE] + [V]

6.4.4 Timer set

To activate the timer function, you need to set the start and end time of the timer. The water heater will run automatically based on the timer set.

6.4.4.1 Start time set

If there is no timer activated, the display will show up like Figure 2.4 once you press TIMER button.

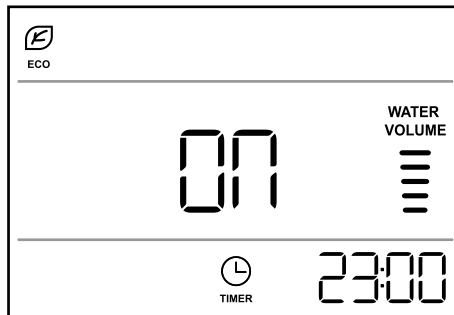

Figure 2.4 Start time set

- ON will be displayed which means you are setting the start time of timer.
- The clock icon will appear with the hour value flashing.
- Press \wedge or \vee button to change the hour value.
- Press SET button to confirm the hour set and the minute value will flash.
- Press SET button to confirm the start time set and switch to end time set.

6.4.4.2 End time set

After confirming the start time set, the display will show up like Figure 2.5.

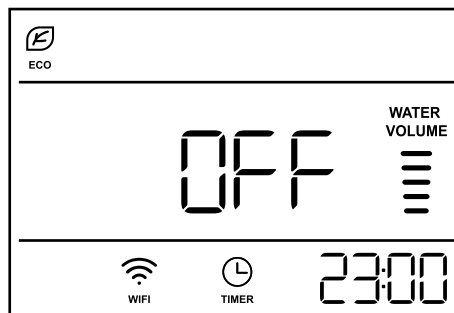

Figure 2.5 End time set

- OFF will be displayed which means you are setting the end time of timer.
- The clock icon will keep appearing with the hour value flashing.
- Press \wedge or \vee button to change the hour value.
- Press SET button to confirm the hour set and the minute value will flash.
- Press \wedge or \vee button to change the minute value.
- Press SET button to confirm the timer setting.
- After finishing all these steps, the display will show up like Figure 2.6. And the timer icon will be displayed all the time.

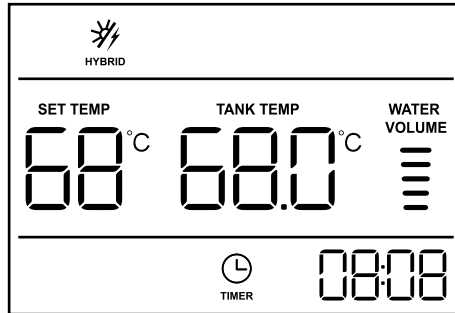

Figure 2.6 Main interface with timer

- When the start time is the same as the end time and the water heater is running, it will shut down.
- When the start time is the same as the end time and the water heater is off, it will turn on.
- Press \odot button could exit the timer setting which won't be saved.
- If there is no operation for 15 seconds, the water heater will exit the timer setting and won't save the settings.

6.4.4.3 Cancel the timer

To cancel the timer function, you need to press the TIMER button.

- The timer icon will not be displayed;
- The start time and end time will be saved as default time;
- After finishing all these steps, the display will show up like Figure 2.7;

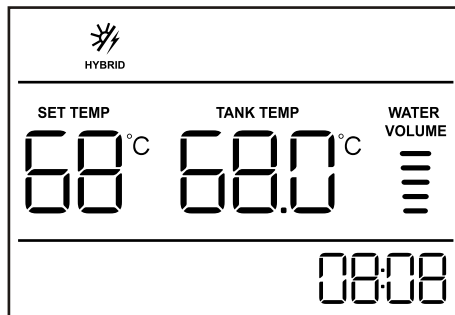

Figure 2.7 Main interface without timer

6.4.5 Sterilization function

- For residential model, when the accumulated operating time exceeds 7 days and the water heater is running, it will run in sterilization mode automatically.

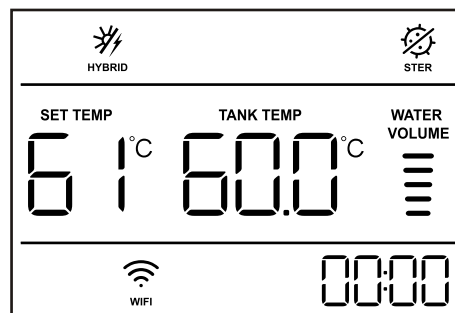

Figure 2.8 Sterilization interface

- For commercial model, the sterilisation for commercial models is achieved by daily boost of 45%+ volume to 60 C+ daily.

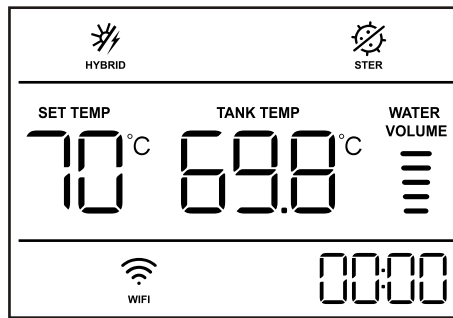

Figure 2.9 Sterilization interface

6.4.6 Wifi function

- Press SET and (⏻) button at the same time to connect wifi;
- The wifi icon will keep flashing when you are connecting the unit;
- If the connection is successful, the wifi icon will stop flashing and be displayed. Otherwise the icon won't be displayed 3 minutes later.

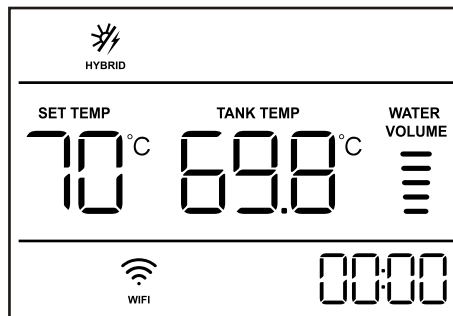

Figure 2.10 Wifi connection

6.4.7 Remote control

You could control the water heater through the Wifi including set the target temperature/running mode/timer, etc

- You need to match the wifi first;

6.4.8 Smart Grid function

- When the water heater received the closed signal from the dry contact which means the Smart Grid function is activated, the SP will be displayed in set temperature zone and the heat pump will increase the target temperature using the free energy.
- The running mode will automatically switch to Standard mode;
- When the water heater received the open signal from the dry contact which means the Smart Grid function is invalid, the SP will not be displayed in set temperature zone and the water heater will run in the mode you set.
- When the water heater is power off, PV dry contact signal won't be implemented.
- You need to connect the KP port in display board.

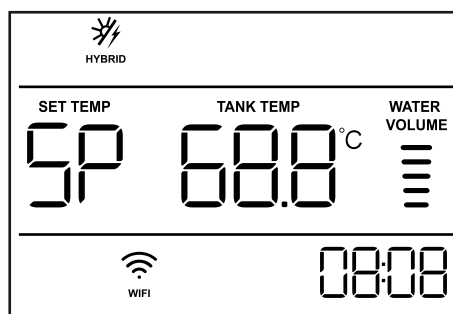

Figure 2.11 Smart Grid function

6.4.9 DRED mode

- Function overview The Australian National Grid Certification (DRED) is a government-mandated energy efficiency requirement designed to alleviate local peak power shortages. The government uses unified deployment to shut down the hot water heater compressor or limit the power consumption of the air conditioner to reduce the power consumption of the air conditioner: when unit gets DRM1 signal, the compressor stops running, and the outdoor fan also stops; When unit gets DRM2 signal, the maximum operating frequency of the compressor is 50% of the normal operating frequency, other operations are normal; When unit gets DRM3 signal, the maximum operating frequency of the compressor is 75% of the normal operating frequency, other operations are normal.

6.4.10 OTA function

- In order to increase the efficiency of servicing, we provide OTA function to you. You can update the unit through Wifi;
- You need to keep the Wifi stable;
- Upgrading confirmation will be confirmed in the APP.

6.4.11 Anti-freezing function

- We provide smart anti-freezing control to prevent any freezing in water heater;
- The water heater will turn on when anti-freezing function is activated. Please keep the water heater powered on.

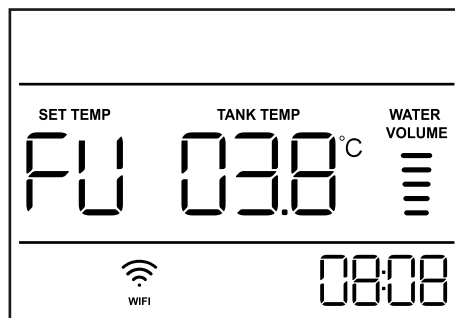

Figure 2.14 Anti-freezing on

6.4.12 Child lock function

- Press the "Mode" button and hold for 3 seconds to turn on/off child lock function;
- If you turn on the child lock function, you can't change any parameters;

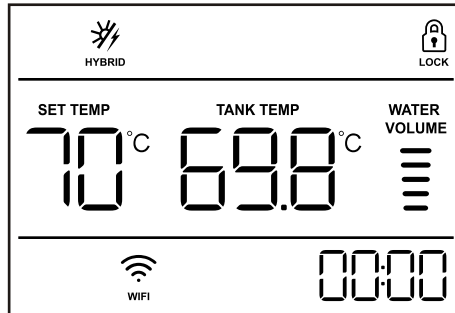

Figure 2.15 Child lock on

6.4.13 Parameter query

- Press MODE and ^ button at the same time and hold for 3 seconds, you could check the parameters of water heater;
- The clock zone will display qUE to remind you are in parameter query interface;

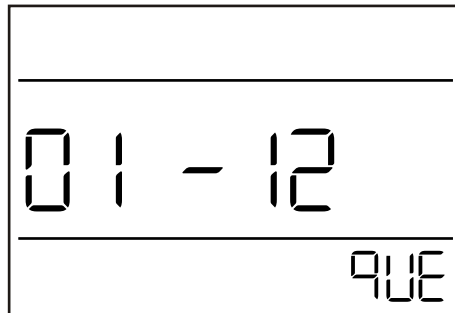

Figure 2.15 Parameter query interface

- The number of parameter will be displayed in Set Temperature zone which will keep flashing once each second.
- The value of parameter will be displayed in Tank Temperature zone and keep lighting up.

Code name	Number	Note
Tank Temperature 1 (Thw1)	01	°C
Tank Temperature 2 (Thw2)	02	°C
Ambient Temperature (Ten)	03	°C
Coil Temperature (Tfr)	04	°C
Discharge Temperature (Tcomp)	05	°C
Sunction Temperature (Tba)	06	°C
4-Way Valve	07	00: OFF 01: ON
Electronic expansion valve	08	Step
Mode	09	00: ECO 01: Hybrid 03: Standard
Set Temperature (Ts)	10	°C
PCB software version	11	
Display software version	12	
Error code	13	The last error code
Error code	14	The second last error code
Error code	15	The third last error code
Error code	16	The fourth last error code

- Press ^ or V button could change the parameter you want to check;

7 BEFORE FIRST USE

Please confirm the following before first using the system:

- the unit is installed correctly;
- the piping and wiring are correct;
- the drainage is smooth;
- the insulation is well done;
- the air in the water pipeline is emptied, and all valves opened.

8 MAINTENANCE AND TROUBLESHOOTING

8.1 Maintenance

The water heater has a high level degree of automation, it is necessary to check the unit regularly. If the unit can be effectively maintained for a long time, the operating reliability and service life of the unit will be significantly improved.

- During using and maintaining the unit, the users shall make sure that all safety protection devices in the unit have been properly set before leaving the factory. Do not adjust the unit by yourself;
- Always check whether the water supply solenoid valve of the water system, the safety valve of the water tank, the liquid level controller and the exhaust device work normally, so as to avoid the reduction of water circulation caused by air entering the system, thus affecting the heating capacity of the unit and the reliability of the unit operation;
- Always check whether the wiring of the power supply and electrical system is firmly connected, and whether the electrical components have abnormal actions. If so, they shall be repaired and replaced in time;
- Always check whether the water supply solenoid valve of the water system, the safety valve of the water tank, the liquid level controller and the exhaust device work normally, so as to avoid the reduction of water circulation caused by air entering the system, thus affecting the heating capacity of the unit and the reliability of the unit operation;
- Check whether the water pump and waterway valves work normally, and whether the water pipeline and joints leak;
- The surroundings of the unit shall be kept clean, dry and well ventilated. Clean the air-side heat exchanger regularly (usually from January to February) to maintain good heat transfer effect;
- If the unit is unused for a long time, the water in the pipeline of the unit shall be drained, the power supply shall be switched off, and the protective cover shall be set. Comprehensive inspection of the system shall be done before next start-up;
- When the unit is not operating correctly and the user can't solve the problem, please contact Power Bay Pty Ltd Customer Support for assistance;
- Check and make sure that the power plug and socket are connected properly, and free from overheating.
- In order to ensure the long-term efficient operation of the water heater, it is recommended to open the water pressure valve and discharge for one minute thoroughly, drain and flush the water tank every six months to remove the sediment that may accumulate during operation.
- The water tank is equipped with a magnesium rod to protect the inner container from corrosion and prolong the service life of the water tank. In this process, the magnesium rod is also slowly consumed. In some water environments, magnesium rods react with water. Once magnesium rods are consumed, the tank liner begins to corrode and eventually causes leakage. It is recommended to check the magnesium rod every year or so. If it is consumed, please replace it with a new magnesium rod. For details, please consult Power Bay Pty Ltd Customer Service.
- If hot water is sufficient, it is recommended that users lower the set temperature, which can heat loss and scale generation, save electric energy and prolong the service life of the water heater.
- When the ambient temperature is lower than 0℃ and the water tank is installed outdoors, please take insulation measures for the water inlet and outlet pipes. If necessary, please install pipeline heating devices to avoid freezing the pipelines.

! ATTENTIONS

Guidelines for replacing anode protection rods

- Turn off the power supply of the water heater and the cold water inlet valve;
- Open the hot water faucet to reduce the pressure of the inner;
- Replace with a new anode protection rod and tighten it to ensure reliable sealing, please find the Magnesium Rod replacement Instructions on page 18 for detailed steps to remove the magnesium rod;
- Open the cold water inlet valve until water flows out of the hot water faucet, and close the hot water faucet;
- Turn on the power supply for normal operation.

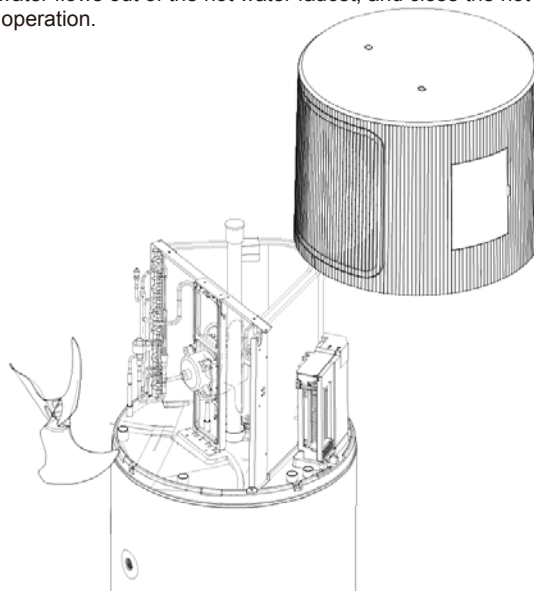

! ATTENTIONS

- If the electric heater cannot be turned on for some reason, check whether the Manual temperature controller above the electric heater is turned off. (The button has been pressed) .

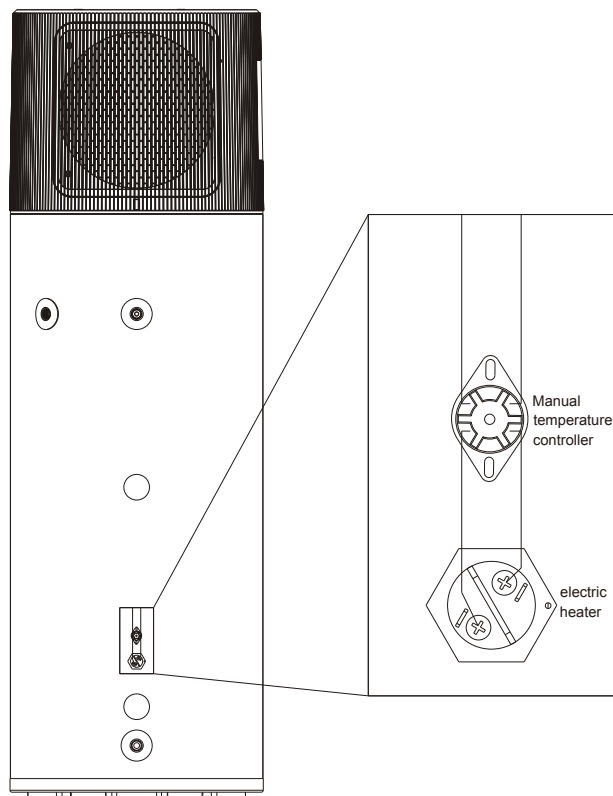

8.2 TROUBLE SHOOTING

When an abnormality occurs in the unit, it will display the error codes shown in the following table.

- Hardware codes and software codes will be displayed in the set temperature zone and flash once per second;
- The reminder code will be displayed in the water tank temperature zone and flash once per second;
- When multiple errors occur at the same time, the error code is updated every 5 seconds.

Error Code	Content	Type	The exclusion method
C8	Defrosting	R	
d1	DEM1 status of DRED	R	
d2	DEM2 status of DRED	R	
d3	DEM3 status of DRED	R	
E0	Communication error	H	Check the main control board and display panel connection cable
E1	Tank Temperature 1 sensor error	H	Check water heater outlet temperature sensor 1
E3	Coil Temperature sensor error	H	Check coil temperature sensor
E4	Ambient Temperature sensor error	H	Check the ambient temperature sensor
E6	Discharge Temperature sensor error	H	Check the discharge temperature sensor
E8	Tank Temperature 2 sensor error	H	Check the water heater outlet temperature sensor 2
EE	EEPROM error	H	Needs to updated EE program
EF	Fan motor error	H	Check whether the fan motor is normal
EH	Suction Temperature sensor error	H	Check the suction temperature sensor
EL	Tank Temperature 3 sensor error	H	Check the water heater outlet temperature sensor 3
F5	PFC protection	S	Compressor overload, emergency protection
F6	Phase protection	S	PCB chip temperature too high, emergency protection
F7	Module temperature protection	S	Abnormal phase current
F9	Module temperature circuit error	S	Compressor Protection (frequency limit/frequency reduction)
FA	Phase current detection error	H	Compressor Current Protection (frequency limit/frequency reduction)
Fb	Over-load limitation	S	PCB chip temperature protection (frequency limit/frequency reduction)
FE	Phase current limitation	H	Compressor protection (frequency limit/frequency reduction)
FF	Module temperature limitation	S	Frequency limit/frequency reduction
FH	Inverter limitation	S	Main board current (frequency limit/frequency reduction)
Fj	Discharge Temperature limitation	S	Compressor overload, emergency protection
Fn	Current limitation	S	PCB chip temperature too high, emergency protection
FU	Anti-freezing protection	R	
H1	High pressure switch error	H	System High Voltage Protection
H2	Low pressure switch error	H	System low voltage protection
P0	IPM protection	S	The unit has protection such as frequency limit/frequency reduction, check whether the ambient temperature exceeds the limit.
P1	Over-voltage protection	S	Check whether the voltage is normal
P2	Over-current protection	S	Unit current is too high
P4	Discharge Temperature protection	S	Discharge temperature is too high
P7	Over-heating protection	S	Water tank temperature is too high
P8	Over-range protection	S	Outdoor ambient temperature exceeds the limit
SF	Refrigerant recycle	R	
SP	SG on	R	

H-Hardware code S-Software code R-Reminding code.

8.3 MAGNESIUM ROD REPLACEMENT

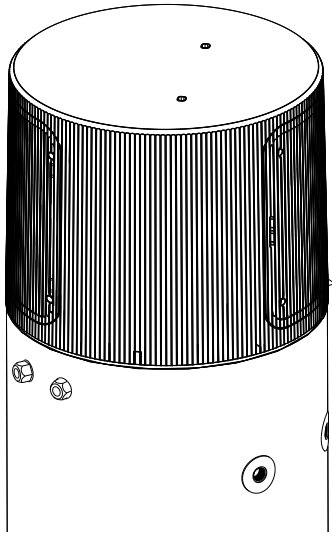

- ① Take out the two screw hole covers on the top, then open the three screw hole covers on the bottom of the top cover, and use cross screwdriver to unscrew those 5 screws;

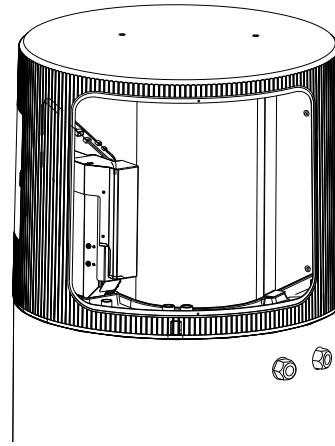

- ② Use cross screwdriver to unscrew 2 screws on the rear grilles, and remove the grilles from the side near the screw holes;

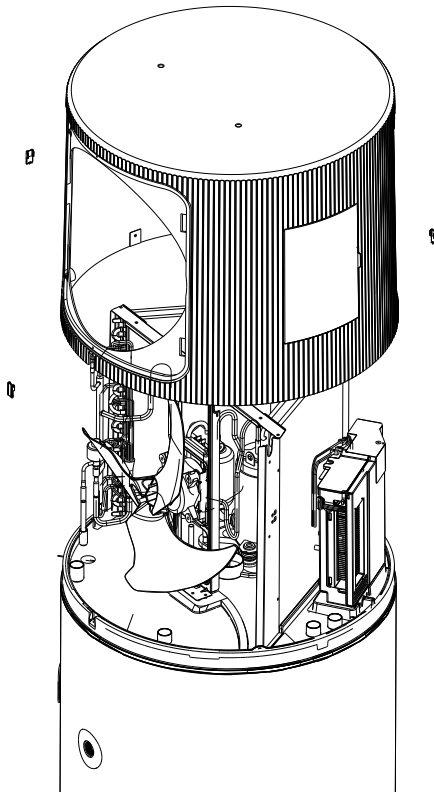

- ③ Separate the connection cable of the display panel from the buckle, and lift the top cover straight upward;

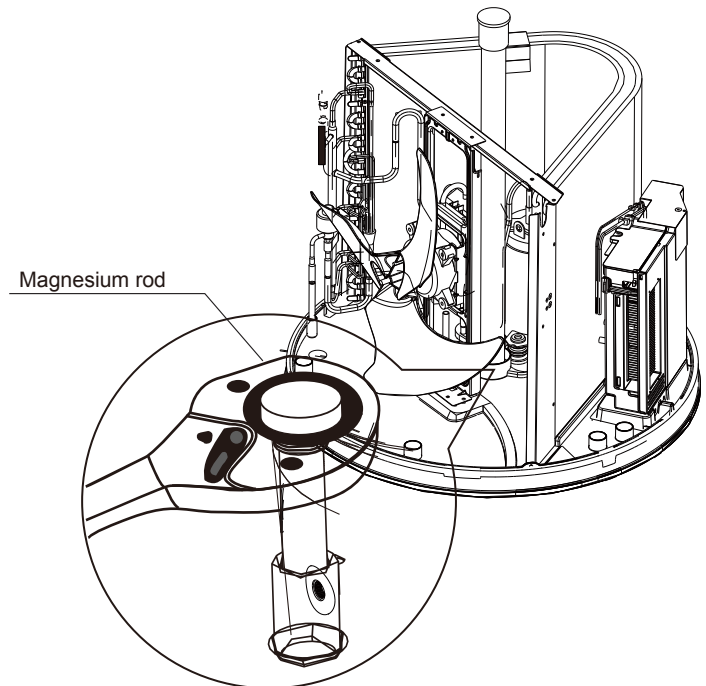

- ④ It is recommended to check magnesium rod consumption regularly, such as annually or biennially.

WARNING

Before replacing the magnesium rod, please confirm the following safety matters !

- The power supply to the unit is completely cut off.
- Cut off the water supply to the water tank to prevent water from overflowing.
- There is enough operating space on the top of the unit.

- Remove screws:
There are 6 screws that need to be removed, 2 on the inlet grille, 2 on the outlet grille, and 2 on the top;
- Disconnect the wiring:
Standing on the side of the air inlet grille, you can see that there are 2 terminal blocks connected to the plugs above the electric control box, and disconnect the 2 connectors;
- Remove the cover:
In the connection area between the cover and the water tank, remove 3 screws and slowly lift up the cover until it is removed;
- Replace magnesium rod:
Magnesium rod is installed in the center of water tray;
You need to use a No. 17 sleeve to turn it counterclockwise. After loosening the screw, you can take out the magnesium rod directly upwards.

9 APP CONNECTION

In order to provide users with a better product experience, the water heater can be connected to the APP for remote control.

- Download Tuya or Smart life app in the Google Play store or the App Store;
- Press SET and  button at the same time to match wifi.
- Follow the guideline to add the unit in the APP.



Tuya Smart App



Smart Life App

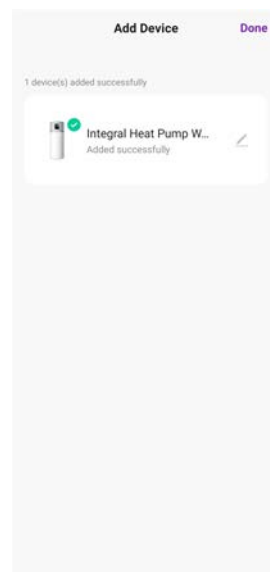
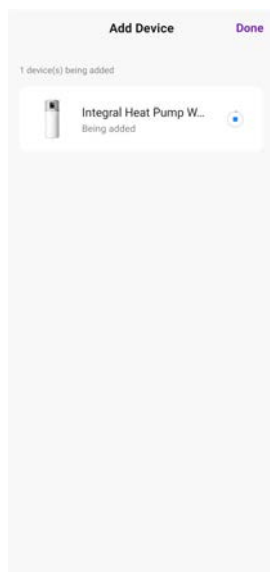
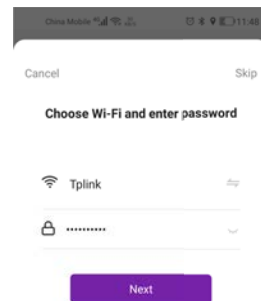
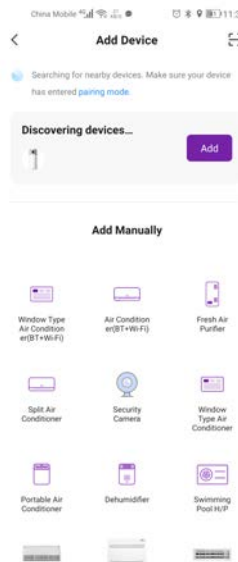
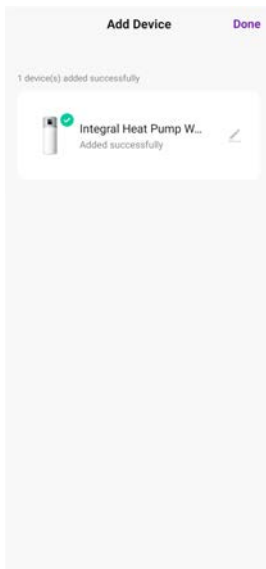

- To ensure the stability of the wifi connection, please install it close to the router;
- If the wifi signal is not stable, please install a wifi repeater;
- Any new installation on another device will remove permissions from the previous device.

